

ECE TYPE-APPROVAL CERTIFICATE



Communication concerning:² ~~Approval granted~~
~~Approval extended~~
~~Approval refused~~
~~Approval withdrawn~~
~~Production definitely discontinued~~

of a type device pursuant to Regulation No. 7

Approval No: **E24*7R02/26*0284*00**

Reason for extension:

N/A

1. Trade name or mark of the device:



2. Manufacturer's name for the type of device:

ZK-01-001

3. Manufacturer's name and address:

**Changzhou Zhongkai Vehicle Parts Co.,
 Ltd.
 Menghe Avenue, Henghe Town, Xinbei
 District, Changzhou City, Jiangsu
 Province P.C.: 213001**

4. If applicable, name and address of manufacturer's representative:

N/A

5. Submitted for approval on:

09.01.2018

6. Technical service responsible for conducting approval tests:

**TÜV SÜD Auto Service GmbH
 Westendstraße 199
 D-80686 München
 Germany**

7. Date of test report issued by that service:

03.01.2018

8. Number of report issued by that service:

17-01915-CX-SHA-00

¹ Distinguishing number of the country which has granted/refused/withdrawn approval (see approval provisions in the Regulation).

² Strike out which does not apply.

Approval No: **E24*7R02/26*0284*00**

9. Concise description:

9.1 By Category of lamps:

Front position lamp A

For mounting ~~either outside or inside or both~~²

Outside

Colour of light emitted: ~~red~~/white²

White

Number, category and kind of light source(s):

1*R10W

Voltage and wattage:

24V and 10W

Light source module specific identification code:

N/A

Only for limited mounting height of equal to or less than 750 mm above the ground (~~yes~~/no):

No

Geometric conditions of installation and relating variations (if any):

See manufacturer's information document

Application of an electronic light source control gear/variable intensity control:

N/A

(a) being part of the lamp: ~~yes~~/no²

N/A

(b) being not part of the lamp: ~~yes~~/no²

N/A



Input voltage(s) supplied by an electronic light source control gear/variable intensity control:

N/A

Electronic light source control gear/variable intensity control manufacturer and identification number (when the light source control gear is part of the lamp but is not included into the lamp body):

N/A

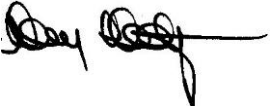
Approval No: E24*7R02/26*0284*00

- Variable luminous intensity: *yes/no*² *No*
- The front position lamp², rear position lamp², stop lamp², end-outline marker lamp², is only for use on a vehicle fitted with a tell-tale indication failure: *yes/no*² *No*
- 9.2 Function(s) produced by an interdependent lamp forming part of an interdependent lamp system:
- | | | |
|-------------------------|----------------------------|-----------|
| Front position lamp | <i>yes/no</i> ² | <i>No</i> |
| R1 Rear position lamp | <i>yes/no</i> ² | |
| R2 Rear position lamp | <i>yes/no</i> ² | |
| S1 stop lamp | <i>yes/no</i> ² | |
| S2 stop lamp | <i>yes/no</i> ² | |
| S3 stop lamp | <i>yes/no</i> ² | |
| S4 stop lamp | <i>yes/no</i> ² | |
| End-outline marker lamp | <i>yes/no</i> ² | |
10. Position of the approval mark: *On the lens*
11. Reason(s) for extension (if applicable): *N/A*
12. Approval granted/extended/refused/withdrawn²: *Granted*
13. Place: *Dublin*
14. Date: *24th January, 2018*
15. Signature:  
16. The list of documents deposited with the Administrative Service which has granted approval, is annexed and may be obtained on request.

Index to the Information Package

Date of issue:	<i>24th January, 2018</i>
Date of latest amendment:	<i>N/A</i>
Reason for extension/revision:	<i>N/A</i>
1. Additional conditions, and advisory notes on legal alternatives.	
2. Test report(s)	
- numbers(s):	<i>17-01915-CX-SHA-00</i>
- date of issue:	<i>03.01.2018</i>
- date of latest amendment:	<i>N/A</i>
3. Information document	
- number(s):	<i>ZK-01-001-00</i>
- date of issue:	<i>14.12.2017</i>
- date of latest amendment:	<i>N/A</i>
Documentation:	<i>10 pages</i>

Approval No: E24*7R02/26*0284*00

Appendix: **Additional conditions, and advisory notes on legal alternatives.**

A: Additional conditions:

1. The device, Type ZK-01-001, shall be marked as prescribed in the regulation.
2. The attached technical report, with any of its attachments, forms part of this Type Approval certificate.
3. Each individual product from series production shall be to the measurements specified in the attached drawings, and shall be manufactured only from the materials specified in the Approval documents.
4. Changes in the product are permitted only with the explicit permission of NSAI. Breaches of this requirement will lead to a withdrawal of the Type Approval, and in addition may be subject to criminal prosecution.
5. This Type Approval will expire when it is surrendered by the holder, or withdrawn by NSAI, or when the approved type of product no longer conforms to legal requirements. The recall of the Type Approval can be issued by NSAI when the conditions required for the issuing or continuation of the Type Approval are no longer current, or when the Approval holder is in breach of the duties attached to the Type Approval, or when it is established that the approved type no longer meets the requirements of traffic safety.
6. NSAI may at any time check the correct performance of the duties imposed by the grant of this Type Approval, and in order to do so, may make tests, or have tests made.
7. Changes in the company name, address or manufacturing site, as well as in any of the sales or other agents specified in the issuing of the approval must immediately be notified to the NSAI.
8. The duties imposed by the issuing of this certificate are not transferable. The legal protection of third parties is not affected by this certificate.
9. When the manufacture or sale of the vehicle, system, component or separate technical unit has not been started within one year of the date of issue of this certificate, then NSAI is to be informed. This requirement also applies when the manufacture or sale has been halted for more than one year, or when it ought to have been halted for more than one year. The initial commencement of manufacture or sale, or the resumption of manufacture or sale, shall then be notified to NSAI within one month of commencement or resumption.

B : Legal Options

Any objection to the requirements set out in this certificate shall be made within one month of the date of issue. The objection shall be made, in writing, to NSAI in Dublin.



Technical Report No.: 17-01915-CX-SHA-00
Manufacturer: Changzhou Zhongkai Vehicle Parts Co., Ltd.
Type: ZK-01-001

TECHNICAL REPORT

No.: 17-01915-CX-SHA-00

Test according to ECE regulation relating to

Front position lamp A

ECE Regulation No.: 7

supplement 26 to the 02 series of amendments

Approvals granted up to now		
ECE	Number of approval	Date
	---	---

Technical Report No.: 17-01915-CX-SHA-00
Manufacturer: Changzhou Zhongkai Vehicle Parts Co., Ltd.
Type: ZK-01-001

Page 2 / 7

I. Technical description

- 0.1. Make (trade name of manufacturer) : 
- 0.2. Type : ZK-01-001
- 0.2.1. Variants : N/A
- 0.3. Means of identification of type : By digits and letters
- 0.4. By category of lamp : Front position lamp A
- For mounting either outside or inside or both : Outside
- Color of light emitted : White
- Number, category and kind of light source(s) : 1*R10W
- Voltage and wattage : 24V and 10W
- Light source module specific identification code : N/A
- Only for limited mounting height of equal to or less than 750 mm above the ground : No
- Geometrical conditions of installation and relating variations, if any : See manufacturer's information document
- Application of an electronic light source control gear/variable intensity control
- Being part of the lamp : N/A
- Being not part of the lamp : N/A
- Input voltage(s) supplied by an electronic light source control gear/variable intensity control : N/A

Technical Report No.: 17-01915-CX-SHA-00
Manufacturer: Changzhou Zhongkai Vehicle Parts Co., Ltd.
Type: ZK-01-001

Page 3 / 7

Electronic light source control gear/
variable intensity control manufacturer
and identification number (when the
light source control gear is part of the
lamp but is not included into the lamp
body) : N/A

Variable luminous intensity : No

The front position lamp is only for use
on a vehicle fitted with a tell-tale
indicating failure : No

Function(s) produced by an interdependent lamp forming part of an interdependent
lamp system:
Front position lamp : No

0.5. Name and address of manufacturer : Changzhou Zhongkai Vehicle Parts Co.,
Ltd.
Menghe Avenue, Henghe Town, Xinbei
District, Changzhou City, Jiangsu
Province P.C.: 213001

0.8. Address of assembly plant : See 0.5.

0.9. Location of the approval mark : On the lens

0.10. If applicable, name and address of the
manufacturer's representative : N/A

Technical Report No.: 17-01915-CX-SHA-00
Manufacturer: Changzhou Zhongkai Vehicle Parts Co., Ltd.
Type: ZK-01-001

Page 4 / 7

II. Test record

1. Test conditions

- 1.1. Technical data of the test samples : Two samples were tested.
Sample No. 1, left side mounting.
Sample No. 2, right side mounting.
For information about the form of the lamp, the position of the reference point and the reference axis, see information document.
- 1.2. Test procedures used : According to ECE Regulation No.: 7.02.
- 1.3. Measuring and test equipment : Full automatic photometric test system for automobile lamps
EVERFINE PHOTO-E-INFO CO.,LTD
Type GO-HD5

2. Test results

2.1. General Specifications

The devices have been designed and constructed that in normal conditions of use, and notwithstanding the vibrations to which they may be subjected in such use, their satisfactory operation remains assured and they retain the characteristics prescribed by this Regulation.

No light source module or light generator is used.

2.2. Intensity of light emitted

2.2.1. Sample No. 1 and sample No.2, test voltage 14.109V

No.	Point of the measurement		Limits [cd]		Measured values [cd]		Conclusion
			Min.	Max.	Sample No. 1	Sample No. 2	
1	5L	10U	0.80	140.00	26.13	24.28	Complies
2	5R	10U	0.80	140.00	27.76	28.41	Complies
3	20L	5U	0.40	140.00	9.32	24.61	Complies
4	10L	5U	0.80	140.00	14.08	26.02	Complies
5	H	5U	2.80	140.00	49.98	44.16	Complies
6	10R	5U	0.80	140.00	22.58	17.27	Complies
7	20R	5U	0.40	140.00	21.04	10.05	Complies
8	10L	V	1.40	140.00	33.29	20.67	Complies
9	5L	V	3.60	140.00	44.34	18.23	Complies
10	H	V	4.00	140.00	35.96	38.18	Complies
11	5R	V	3.60	140.00	15.98	55.52	Complies
12	10R	V	1.40	140.00	12.56	49.41	Complies
13	20L	5D	0.40	140.00	10.04	20.66	Complies
14	10L	5D	0.80	140.00	13.97	24.02	Complies
15	H	5D	2.80	140.00	13.40	18.22	Complies
16	10R	5D	0.80	140.00	20.03	16.59	Complies
17	20R	5D	0.40	140.00	16.46	12.02	Complies
18	5L	10D	0.80	140.00	13.99	14.05	Complies
19	5R	10D	0.80	140.00	14.02	18.22	Complies
20	All directions Min.		0.05	---	1.29	2.18	Complies
21	All directions Max.		---	140.00	52.25	59.94	Complies

Technical Report No.: 17-01915-CX-SHA-00
 Manufacturer: Changzhou Zhongkai Vehicle Parts Co., Ltd.
 Type: ZK-01-001

Page 6 / 7

2.3. Colour - White

	Measured values		Limits
Sample	x	y	W12 green boundary: $y = 0.150 + 0.640 x$ W23 yellowish green boundary: $y = 0.440$ W34 yellow boundary: $x = 0.500$ W45 reddish purple boundary: $y = 0.382$ W56 purple boundary: $y = 0.050 + 0.750 x$ W61 blue boundary: $x = 0.310$
No. 1	0.3987	0.3829	Complies
No. 2	0.3992	0.3831	Complies

2.4. Apparent surface

Limit (O)	Limit (I)	Limit (U)	Limit (D)
33mm	40mm	22mm	22mm

3. Specimen submitted to test on : 2017-12-14 (YYYY-MM-DD)
4. Place of test : Jiangsu Huachen Vehicle Inspection Co., Ltd., Zhenjiang City, P.R. China
- Date of test : 2017-12-19 (YYYY-MM-DD)

III. Enclosures

- Manufacturer's information : ZK-01-001-00
 document No.
- Dated on : 2017-12-14 (YYYY-MM-DD)

Technical Report No.: 17-01915-CX-SHA-00
 Manufacturer: Changzhou Zhongkai Vehicle Parts Co., Ltd.
 Type: ZK-01-001

IV. Statement of conformity

The information folder as mentioned under No. III and the type described therein are in compliance with the test specification mentioned above. The worst-case was selected in accordance with document "Preparation of Test Reports".

The test report may be reproduced and published in full and by the client only. It can be reproduced partially with the written permission of the test laboratory only.

München, 2018-01-03
 (YYYY-MM-DD)



Joe Zhou

Test Laboratory / DIN EN ISO 17025

Genehmigungsbehörde/ Approval authority	Land/Country	Registriernummer/ Registration-number	Aktueller Benennungsumfang/ Actual scope list
Kraftfahrt-Bundesamt (KBA)	Deutschland/ Germany	KBA-P 00100-10	www.kba.de
Vehicle Certification Agency (VCA)	Vereintes Königreich/ United Kingdom	VCA-TS-006	http://ec.europa.eu/enterprise/sectors/automotive/approval-authorities-technical-services/technical-services/index_en.htm
Approval Authority of the Netherlands (RDW)	Niederlande/ The Netherlands	RDWT-082-XX	
National Standards Authority of Ireland (NSAI)	Irland/ Ireland	Technical Service Number: 49	
Vehicle Safety Certification Center (VSCC)	Taiwan/ Taiwan	DE04-06-2	http://www.vsc.org.tw/English/Default.aspx

Information folder No. : ZK-01-001-00

First application date : December 14, 2017

1. Specification data

Type		ZK-01-001			
Function		Front group lamp			
		Head lamp		Front position lamp	Front direction indicator lamp
		Passing beam	Driving beam		
Color		White	White	White	Amber
Rated	Voltage	24V	24V	24V	24V
	Wattage	70W	70W	10W	21W
Application Regulation ECE		R112.01 Class B PL RHT		R7.02 A	R6.01 Cat. 1a
Location of marking	Number and category of light source	H1	H1	R10W	PY21W
	Trade mark	Marked on housing			
					
	Approval mark	Marked on lens			
Remark		The lamp is only for use on a vehicle fitted with a tell-tale indicating failure: No Sequential activation of light sources: No			

2. Construction and material

Construction		Material	Remarks
Outer lens		PC	Make: Bayer AG Type: Makrolon, AL 2647- hue 55/396 Coating and Coating System: Make: Red Spot Paint & Vamish Co. Inc. Evansville, Ind. USA Type: UVT 200 Q1
Inner lens	P.B.	Glass	Colour: Clear
Reflector	P.B.	BMC	AL vacuum vapour coating Painting on the inside surface Colour: Metal silver
	D.B.	BMC	
	F.P.L.	PC	
	F.D.L.	PC	
Housing		PP	Colour: Black
Electrical Wiring		Copper covered with insulation	--

3. Name and address of manufacturer : Changzhou Zhongkai Vehicle Parts Co., Ltd.
Menghe Avenue, Henghe Town, Xinbei District,
Changzhou City, Jiangsu Province P.C.: 213001

4. Name and address of the assembly plant : See 3.

5. Name and address of the manufacturer's representative : N/A

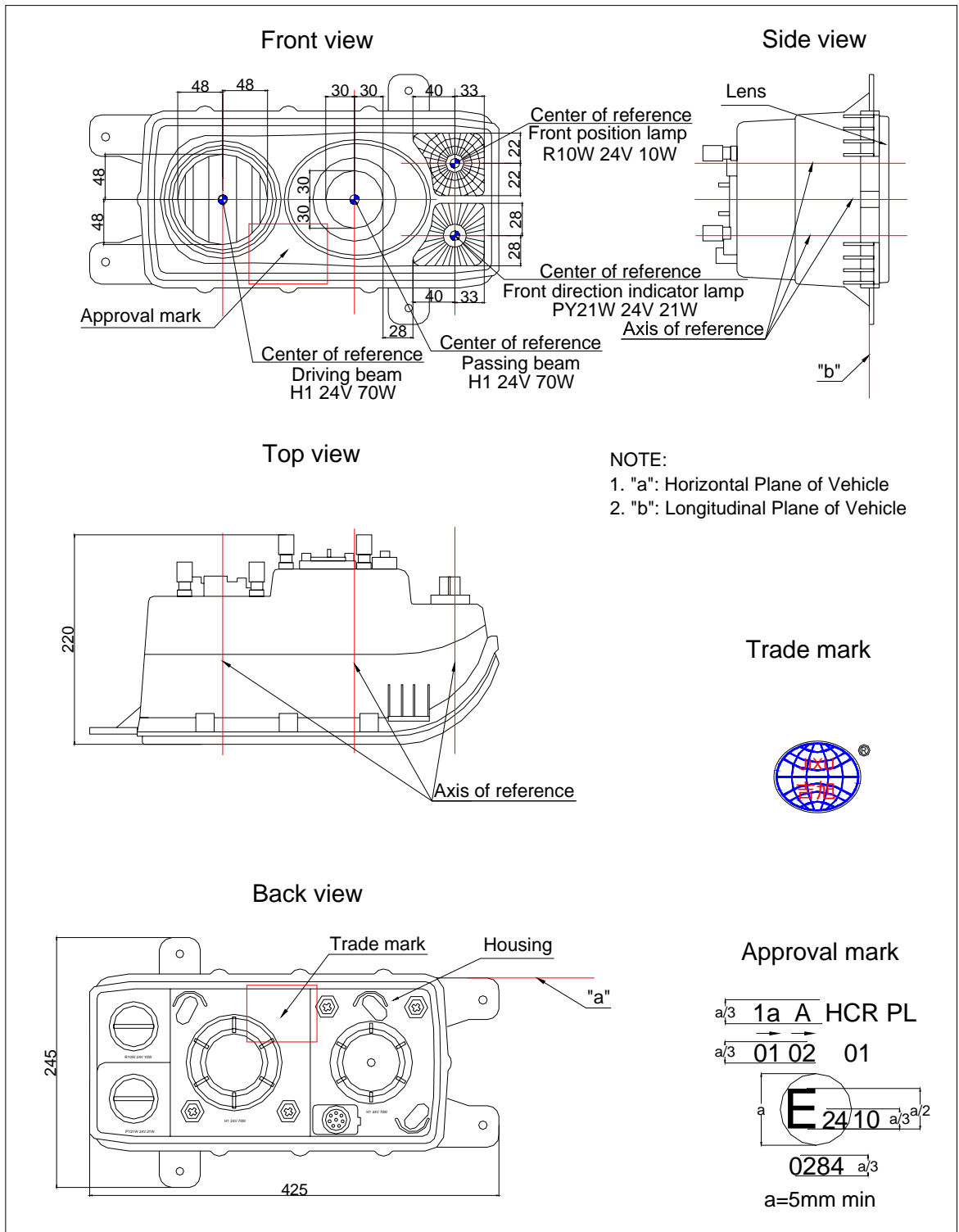

Product Type	ZK-01-001
General assembly drawing (Left side)	
Drawing No.	ZK-01-001-01

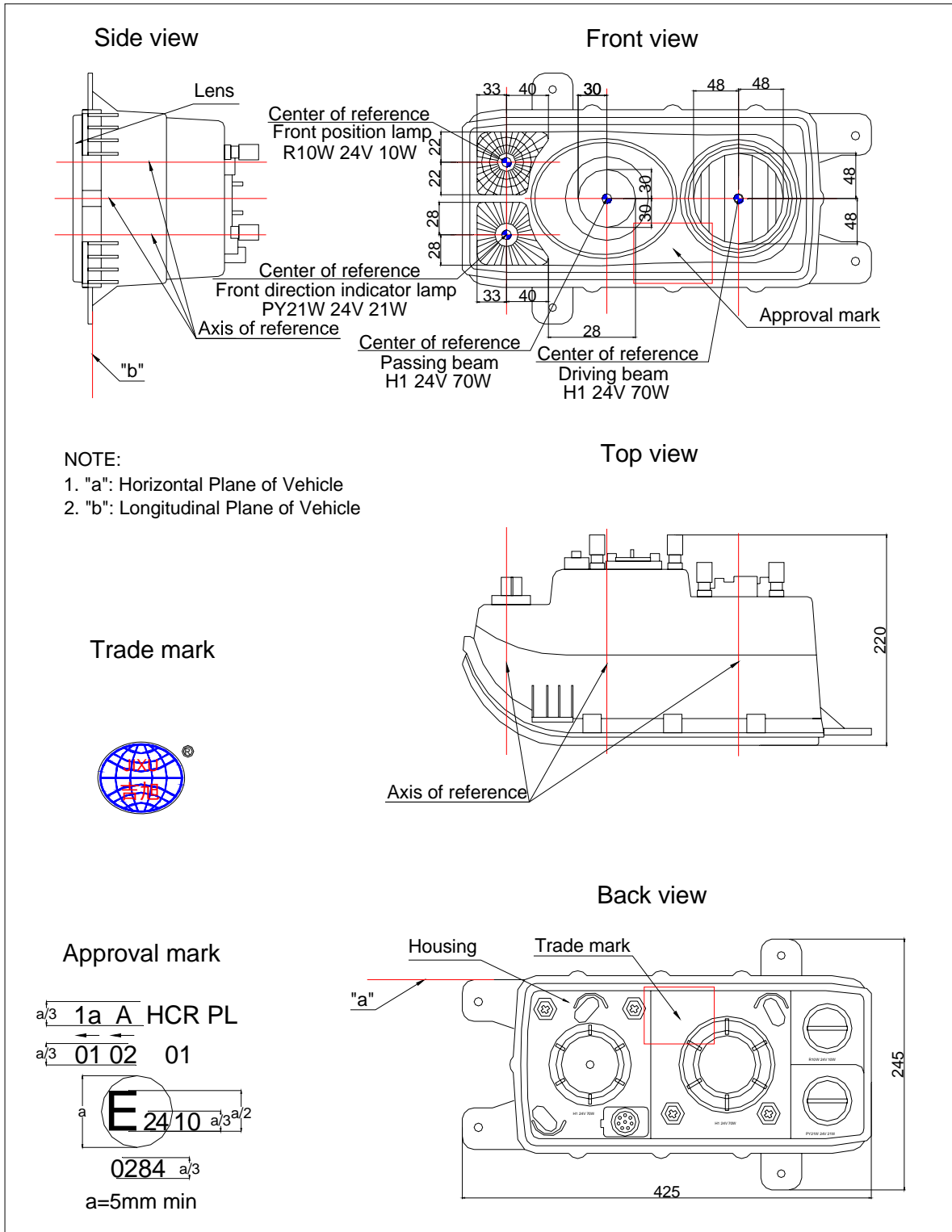

Product Type	ZK-01-001
General assembly drawing (Right side)	
Drawing No.	ZK-01-001-02